

# WINMATE

*Oil and Gas-Grade Solutions*

## **RUGGED HMI TECHNOLOGY FOR HAZARDOUS AREAS AND EXTREME ENVIRONMENTS IN THE OIL & GAS INDUSTRY**



**White Paper**

## **TECHNOLOGY FUELS EXPLORATION**

**Vol. 2 - 2021**

## Introduction

Oil rigs and remote pipeline locations are some of the most dangerous and challenging work environments anywhere. When looking for electronics to support these environments, devices must stand up to three essential requirements:

1. Provide advanced system monitoring even in the most challenging conditions
2. Accurately identify and track assets and communicate data from remote sites
3. Withstand the highest scrutiny of certification and inspection

Because the conditions are risky for personnel and equipment, reliable and accurate monitoring is crucial to maintaining safe operations. In addition, computers at these working locations must also maintain detailed data on, for example, petroleum exploration and transportation. To meet the safety qualification, Winmate offers ATEX and Class 1 Division 2 (C1D2) certified solutions for maintaining safe operations and collecting detailed, sensitive data in the remote rig and pipeline locations.

**Petroleum Exploration and Production - Upstream Processes** Traditional complex function sleek through dangerous HMIs developed for the electricity industry consist of measurement-while-drilling (MWD), flourishing logging, downhole function, twist command, and arrow boring. However, harmful processing innovation permits designers and drivers accessibility to finalize surveillance of essential efficiency information and equipment management in rough operating ailments. For this cause, functions generally decide for sleek, lightweight dangerous personal computers and displays that can easily be actually quickly installed to use additional management, closer to the size devices and punch websites.

Oil exploration and production, including onshore, refining and petrochemical, and offshore drilling, make up the upstream processes in the petroleum sector. Typical upstream operations streamlined by hazardous HMIs explicitly designed for the energy sector include measurement-while-drilling (MWD), thriving logging, downhole operation, torque control, and directional drilling. Hazardous computing technology allows operators and engineers access to close monitoring of critical performance data and machine control in harsh operating conditions. For



this reason, operations typically opt for a compact, lightweight hazardous computers and monitors that can be easily mounted to offer more control, closer to the measurement tools and drill sites. With easy, readable access to real-time performance data, operators can make critical decisions, such as wellbore position, drill bit information, directional data to manage the reservoir's production levels and fluid flow. This enables them to maximize healthy performance and longevity in both extractions of conventional oil, and shale oil rely on hazardous computing technology.



### **Petroleum Processing, Storing and Transporting**

- After extraction through the upstream process, petroleum is processed, stored, and transported to the midstream sector. Hazardous computing technology is critical in the critical functions of the midstream cycle: distribution, storage, blending, inventory management, and additive injection services for the end-users of petroleum products. Like the function of hazardous technology in the upstream processes, operations in the midstream sector utilize the same rugged computers to monitor performance and control processing technology for all of these processes and environmentally challenging applications, including tanker ships, pipelines, and storage facilities. For example, a typical application for fully rugged computers monitors and manages fuel flow in pipelines for the midstream sector. With reliable technology that gives easy access to flow metrics and pipeline performance, operators can quickly detect and respond to any critical issues, such as leaks.

**Petroleum Refining** - The sector depends on harmful place category bodies to illustrate the unsafe situations of exact locations and, thereby, guarantee the tools may safely and securely perform in those circumstances. Northern American possesses the NFPA distinction body, and also Europe possesses the IECEx ATEX Directive that illustrates the settings and the risk-free installment and company methods to sustain the very little threat of power problems. For the oil as well as gasoline business, the very most appropriate categories for unsafe HMIs are actually as complies with: For frequent functioning functions where there are combustible attentions of combustible gasoline or even water vapors are generally current, the unsafe computer system has to be checked as well as authorized for IECEx Zone 1 atmospheres or even Class I, Division 1 atmospheres.

In each midstream and complex industry, dangerous computer systems possess an essential duty to keep procedures and may not jeopardize break down functional damages or even blast. To protect people and equipment, the oil and fuel market demands modern technology along with exclusive electrical wiring and power parts that reduce electric breakdown or even blasts. Through this industry-specific crafted style for the source establishment, unsafe PPCs can quickly work efficiently and correctly in regions where combustible fuels, dirt, or even water vapors might exist. For the oil and gas industry, the most relevant classifications for hazardous HMIs are as follows: For regular working operations where there are ignitable concentrations of flammable gasses or vapors are typically

present, the hazardous computer must be tested and approved for IECEx Zone 1 environments or Class I, Division 1 environments. This extremely durable technology can safely be used near the well or borehole with this classification or rating. As mentioned above, it helps monitor critical processes such as measurement-while-drilling (MWD), thriving logging, downhole operation, torque control, and directional drilling. Common phrases used to describe this technology would be flameproof and explosion-proof.

A more prevalent need in the oil and natural gas market is a hazardous computing technology that can reliably and safely operate in areas when ignitable concentrations of flammable gasses or vapors are not present in normal working conditions but may occur during system failure. This may sometimes be an environment near a Division 1/Zone 1 environment or where the ignitable concentrations of flammable gases are contained during standard operations. These units are designed, tested, and rated for IECEx Zone 2 or Class I, Division 2 environments.

Investing in safe technology is critical for the oil and gas industry, which is why hazardous PPCs and displays are also designed to withstand the jolts, shocks, and vibrations that the oil and gas equipment creates when drilling into hard surfaces; similar to the vibrations created in manufacturing facilities. Contained inside are a solid-state hard drive with no moving parts and temperature controls; these elements protect the unit from damage, freezing, or overheating when enduring shock, vibrations, jolts, and extreme temperatures from -20°C to 60°C (-40°F to 140°F).

The hazardous PPCs technology used in oil and gas extraction, refining, and distribution must be designed to meet and pass rigorous testing to operate in challenging environmental elements, including ultraviolet rays, extreme temperatures, saltwater, hose-directed water, chemicals, jolts, vibrations, and flammable gases. In this business, quickly and accurately interpreting critical data can mean the difference between success and failure. With Rugged HMI PPCs, you can quickly process, interpret, and analyze the data associated with your projects. We've got you covered, from analyzing and interpolating well logs to velocity modeling, pre-stack imaging, and interpretation. Solving the oil and gas market challenges starts with harnessing the power to run complex simulations, data processing, and imaging.

For more than 25 years, Winmate Communication, Inc. has been the global leader in developing advanced rugged, mobile technologies for industries operating in some of the most challenging environments. These include warehouse and logistics, oil and gas, supply chain, field service, transportation, retail, and healthcare. Built on a foundation of operational excellence and innovative technology, Winmate is more than just a storefront for clients. From research and development to manufacturing and in-house testing, we manage the entire product development process to ensure you have access to the most robust, current, safe, and rugged mobile technologies available. Whether tracking a fleet, mapping a mine, or monitoring equipment and production on an oil rig, Winmate provides various rugged form factors with flexible connectivity and data collection and management options.

### Industrial Challenges

■ **Extreme operating environment** - Equipment should provide advanced system monitoring even in the most challenging conditions: potential explosive atmospheres, varying temperature, explosion to water, and rain.

■ **Remote locations** - The devices must accurately identify and track assets and communicate data from remote sites to enable real-time data monitoring and communications.



■ **Environmental regulations** - All the devices for oil & gas applications must withstand the highest scrutiny of certification and inspection.

## Innovative Technology

It is required by law and legislation by countries worldwide that electrical equipment must be designed and manufactured for safe use in environments or atmospheres that may be potentially flammable or explosive. These hazardous areas are flammable gases or vapors, flammable liquids, combustible dust, or ignitable fibers or flyings. At oil and gas production operations and facilities, these hazards and dangers are commonplace. In addition, flammable or explosive substances may be present in varying quantities at all times, so fire and explosion protection and safety certifications for all electrical equipment used in these operations are mandatory.

Winmate has technology know-how for the production and development of explosion-proof devices.

■ **Intrinsic Safety Schematic Design** - The electronic system's schematic design must ensure that the temperature under all fault conditions can never rise to a value that may cause the ignition of explosive gasses. Therefore, our engineers design the intrinsic safety schematics for the explosion-proof product line.

■ **Non-Sparking Device** - Intrinsically safe design means igniting a hazardous atmosphere (explosive gas or dust) cannot occur. This is achieved by ensuring that only low voltages and currents enter the hazardous area and that no significant energy storage is possible. Tout thermal design also prevents device's from overheating.

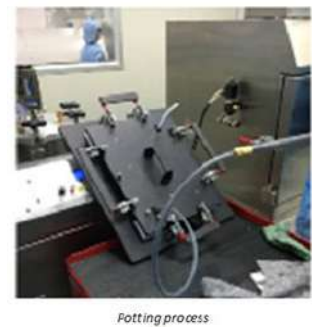
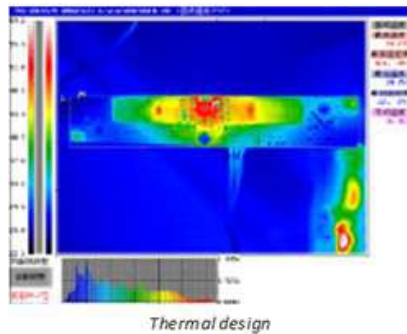
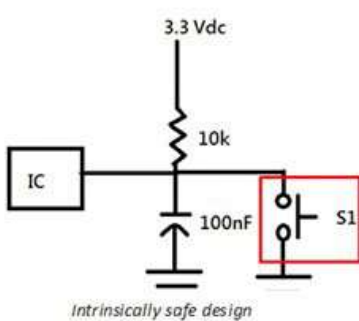

■ **No-Air Potting Process** - Potting is a process of filling a complete electronic assembly with a solid or gelatinous compound for resistance to shock and vibration and excluding moisture and corrosive agents. Winmate performs no-air potting of electronic components in-house. Potting prevents the substrate from failing in harsh environments or from vibrations or other potentially damaging uses.



## Built to withstand the rigors of the harshest environments

Winmate understands the need for ruggedness and uninterrupted productivity when it comes to operating in challenging environments. Our rugged, mobile tablets, handhelds, and fixed-mount displays increase operational efficiencies, integrate seamlessly into enterprise, and deliver low-cost data collection and communications reliability. Whether tracking a fleet, mapping a mine, or monitoring equipment and production on an oil rig, Winmate provides various rugged form factors with flexible connectivity and data collection and management options. Winmate's rugged mobile solutions are built to withstand the rigors of the harshest environments. Every product scrutinizes two standards: Ingress Protection (IP) rating system and the United States Military Standard Environmental Engineering Considerations and Laboratory Tests Standard (MIL-STD). In addition, our rugged mobile devices are built to last, reducing the total cost of ownership over time.

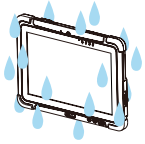
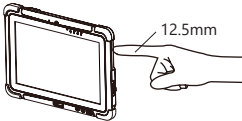
## IP (Ingress Protection) Ratings Guide

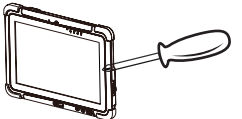
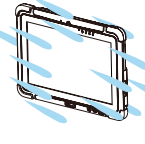
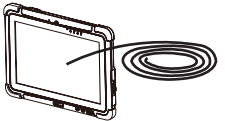
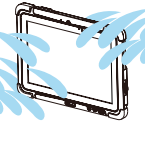
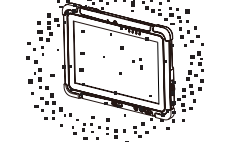
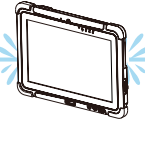
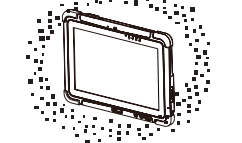
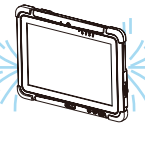
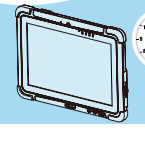
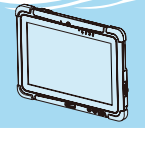

Solids		Waters	
1	 <p>Protected against a solid object greater than 50 mm such as a hand</p>	1	 <p>Protected against vertically falling drops of water. Limited ingress permitted</p>
2	 <p>Protected against a solid object greater than 12.5 mm such as a finger</p>	2	 <p>Protected against vertically falling drops of water with enclosure tilted up to 15 degrees from the vertical. Limited ingress permitted</p>
3	 <p>Protected against a solid object greater than 2.5 mm such as a screwdriver</p>	3	 <p>Protected against sprays of water up to 60 degrees from the vertical. Limited ingress permitted for three minutes.</p>
4	 <p>Protected against a solid object greater than 1 mm such as a wire</p>	4	 <p>Protected against water splashed from all directions. Limited ingress permitted.</p>
5	 <p>Dust Protected, Limited ingress of dust permitted. Will not interfere with operation of the equipment. 2-8 hours</p>	5	 <p>Protected against jets of water. Limited ingress permitted.</p>
6	 <p>Dust tight. No ingress of dust. 2-8 hours</p>	6	 <p>Waters from heavy seas of water projected in powerful jets shall not enter the enclosure in harmful quantities</p>
		7	 <p>Protection against the effects of immersion in water between 15 cm and 1 m for 30 minutes</p>
		8	 <p>Protection against the effects of immersion in water under pressure for long periods</p>

Rating Example:

**IP65**

INGRESS PROTECTION

From an overview perspective, the governing regulating bodies or groups for setting standards for electrical safety and explosion protection by area of region or country include:

REGION/COUNTRY	MARKING	LEGISLATIVE BASIS AND STANDARDS
<p><b>International</b></p>		<p>IEC Ex System, Ex areas can be known by different names such as “Hazardous Locations,” “Hazardous Areas,” “Explosive Atmospheres,” and the like relate to areas where flammable liquids, vapors, gases, or combustible dust are likely to occur in quantities sufficient to cause a fire or explosion.</p>
<p><b>Europe</b></p>		<p>The standards for explosion protection valid in the European Union are created based on the EU directives under the leadership of the European Committee for Electrotechnical Standardization (CENELEC 60 079). EN 60079 and EN 61241 specifically cover the area of explosion protection. CENELEC only defines standards in parallel with the IEC. The CE mark is complemented with the Ex mark, followed by an indication of the Group, Category, and if Group II equipment, the indication relating to gases (G) or dust (D). There are also ATEX directives. These EU directives describing what equipment and work are allowed in environments with an explosive atmosphere. ATEX 95 equipment directive 94/9 EC is for equipment and ATEX 137 workplace directive 99/92/EC is for worker safety.</p>
<p><b>North America</b></p>		<p>In North America, testing for electrical equipment deemed suitable for hazardous areas is performed by nationally recognized testing laboratories such as UL, MET, FM, CSA, or Intertek (ETL). The label will always list the Class(es), Division(s), and may list the Group(s) and temperature Code. Directly adjacent to the label, one will find the mark of the listing agent. The American National Standard Institute (ANSI) is a non-profit organization that coordinates US standards with international standards so that American products can be used worldwide. Other necessary published standards for electrical equipment include API RP 505 (zone system) and OSHA for the US.</p>

CLASS/DIVISION SYSTEMS	DEFINITION
<b>Area</b>	Provides a brief description of the hazardous material present and the probability that it is present. The proper equipment may be selected, and safe installation practices may be followed.
<b>Class</b>	Three categories of hazardous materials are designated by Classes and are defined by the NFPA Publication 70, NEC, and CEC. The Classes define the explosive or ignitable substances which are present in the atmosphere. Class I: Locations where flammable vapors and gases may be present Class II: Locations where combustible dust may be found Class III: Locations where ignitable fibers or flyings may be present
<b>Division</b>	The classes described above are subdivided into two Divisions for further clarification, classification, and identification: Divisions I and Division II. The two divisions define the likelihood of the hazardous material being present in a flammable concentration.
<b>Group</b>	Class II Divisions and I are subdivided into Groups of hazardous material considering air mixtures of gases, vapors, or dust. The Groups define substances by rating their volatile nature about other known substances.
<b>Temperature Class</b>	The temperature class definitions are used to designate the maximum operating temperatures on the surface of the equipment, which should not exceed the ignition temperature of the surrounding atmosphere.

## Comparing Classes/Divisions System with Zone System

To simplify understanding the differences and similarities between the two systems used in North America, Europe, and other parts of the world, a diagram visually identifies the various atmospheric situations and environments in hazardous areas. The diagram also shows how the Class/Division system and the Zone system classify and define them.

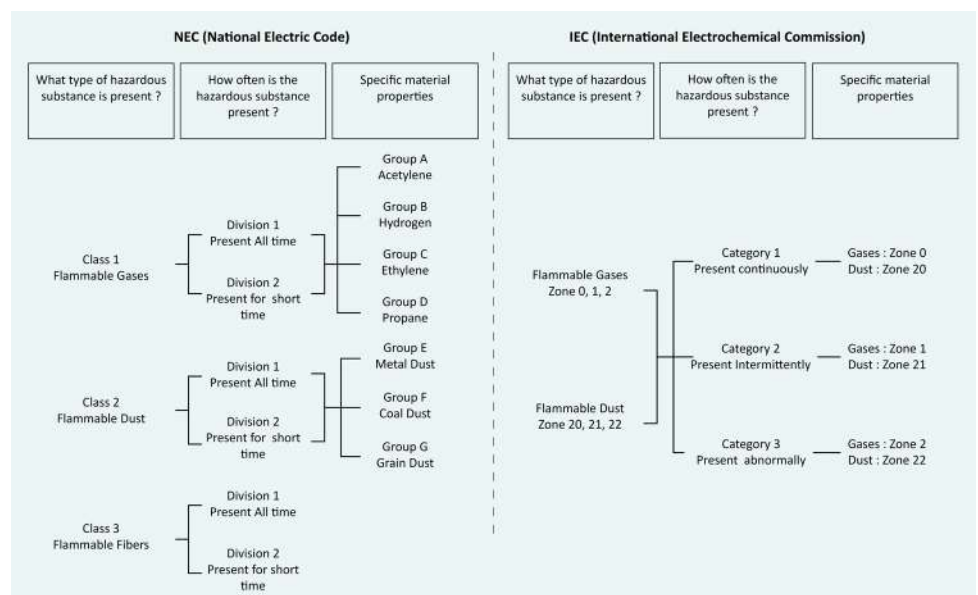

## Technology Options

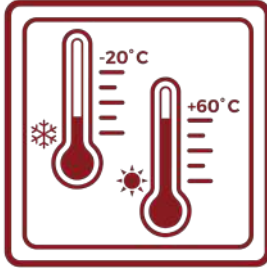

**EXTREME  
TEMPERATURE RANGE**



**INTERNATIONAL  
CERTIFICATIONS**



**IOT READY HMIS**



**WIDE SELECTION  
OF MONITORS**

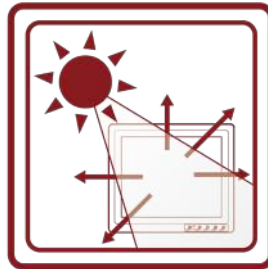

**SUNLIGHT READABLE**



**MODULAR  
& SERVICEABLE**



## Oil & Gas Industry Solution

The oil & gas industry is one of the most dangerous and challenging work environments. Because the conditions are risky for personnel and equipment, reliable and accurate monitoring is crucial to maintaining safe operations. Winmate offers ATEX Zone 2 and Class 1 Division 2 (C1D2) certified panel computers for remote data collection, process visualization, and control. Safe technologies help to improve the productivity, safety, and efficiency of oil refineries. Effectively control processes to lower operation costs and gain more profit. Our computing solutions are deployed in refining and petrochemical applications and have helped many companies improve productivity, safety, and efficiency. One-Stop-Shop Service: HW + SW+ PM+ Factory with all-in-one solution

- ✓ OS: offers Android and Windows-based options with application-focused.
- ✓ Safety Certification: Class/Divisions Systems basics, Zone system basics
- ✓ Product Longevity: 5 ~ 7 Years
- ✓ Standard Warranty: 2 Years
- ✓ Extended Warranty: 5+ Years

**DID YOU KNOW?**

Access to critical information and wireless communications are top priorities for workers to provide fast service. Winmate provides rugged mobile solutions that are capable of increasing productivity in the field.

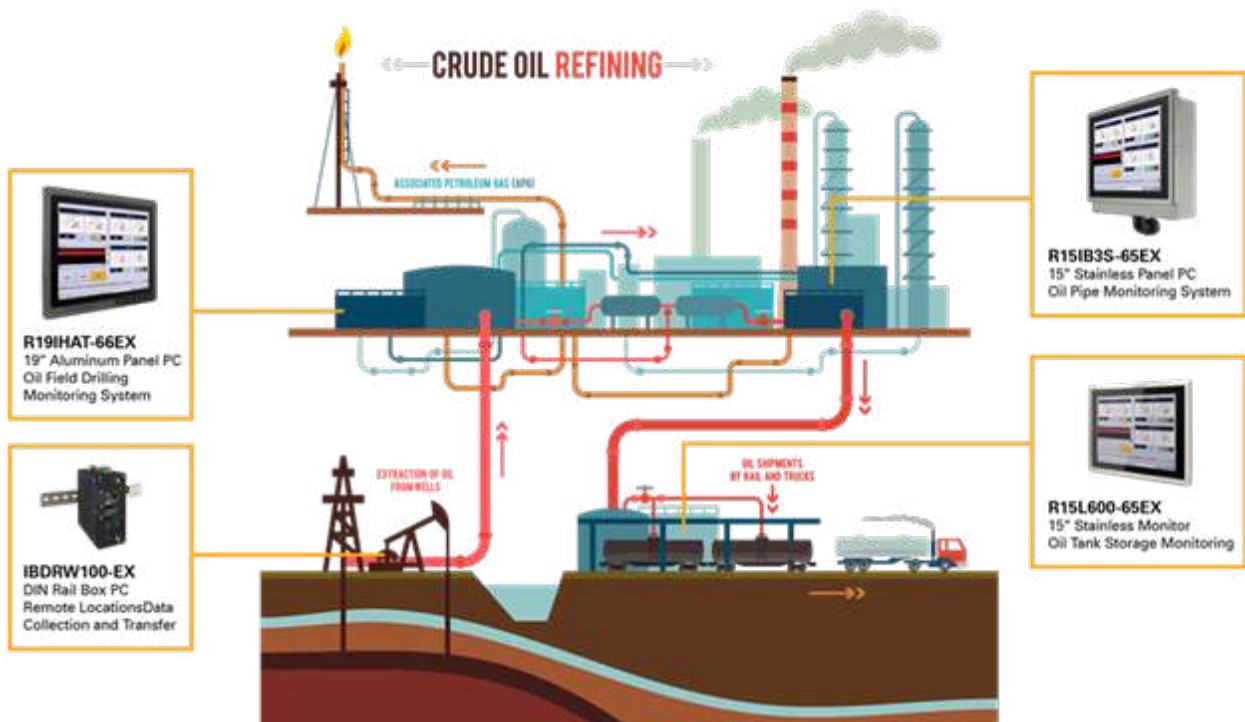

## Winmate Products: Overview

WINMATE offers HMI panel PPCs or touch screen operator interfaces with international approvals for operation and monitoring in hazardous areas with modular designs. WINMATE premium and standard modular panel PPCs are constructed with completely sealed stainless steel type 4/4X, IP 65/66, NEMA 4/4X enclosure with environmental ratings (U.L. 50 or IEC 529) entire HMI system, including fully sealed I/O ports. The touch panel P.C. supports wide operating temperatures from -20 to +60°C, comes with pre-installed Windows 10 IoT Enterprise (LTSB), Windows 9, or Linux operating system, and is powered by Intel® Core™ i5 (Premium IEx Series), Intel® Celeron® (Standard IEx Series), or Intel Atom® (Compact IEx Series) processor. In addition, WINMATE offers ATEX Class I Division 2, ATEX 94/9/EC Zone 2, IEC's IECEx Zone 2 certification on its hazardous locations panel PPCs, and open HMI platforms primarily designed for the volatile and harsh environments of oil, gas, chemicals, and oilfield equipment and services. WINMATE full-range selection of industrial displays is offered in screen sizes ranging from 10.1" to 32".

Winmate explosion-proof rugged computing solutions are designed for nearly any oil and gas application. Our products are tough enough to withstand the most extreme conditions. You can use our products for data collection, personnel monitoring process automation, and many other tasks. In addition, our explosion-proof industrial computers and rugged tablets are designed to integrate seamlessly into your workflow.

### Our rugged mobile computers include:

- Rugged panel PC and HMI: High-resolution display with optical bonding and multitouch screen for comfortable operations and intuitive user control.
- Rugged Mobile tablets: Rugged, flexible, and intrinsically safe mobile tablets. Perfect assistant to any field service works in hazardous locations.

- DIN-rail box PC: Robust and compact box PC for data collection and monitoring from meters and sensors deployed on the field.

### Winmate ATEX HMI and PPCs benefits:

- The open platform enables industry 4.0 and industrial internet of things (IIoT) applications
- UL/CUL listed: Class I, Division 2, Groups A, B, C, D T4; Class I Zone 2, IIC, T4; UL 61010-1
- International approvals for use directly in hazardous areas
- C.E. Ex marked: ATEX II; ATEX Zone 2
- Compliance with IEC 60079-0, IEC 60079-11, and IEC 60079-15
- Modular designs for field-replaceable displays and box P.C. modules
- Dedicated disaster recovery drive for reduced downtime
- Wide operating temperatures range from -20 °C to +60 °C
- 1000 nits, sunlight-readable, and U.V. protective LCDs
- NEMA 4X and IP66 protective stainless-steel enclosure
- Projected capacitive touch operation with thin gloves

### Winmate Rugged HMI Technology Solutions are Suitable for a Wide Range of Applications:

- Oilfield Equipment & Services
- Drilling Rig Systems
- Pipeline Transport
- Drilling Systems Automation
- Local Instrument Rooms
- Machinery Control Systems
- Process Control Systems
- Intelligent Well Systems
- Upstream, Midstream and Downstream Automation

## Summary

Field service workers face various challenges working in remote locations and unfamiliar environments, and every minute of downtime results in lost revenue. Access to critical information and wireless communications are top priorities for workers to provide fast service. Winmate provides rugged mobile solutions that are capable of increasing productivity in the field. Our rugged mobile solutions are built to withstand the rigors of the harshest environments and are designed to improve field workers' efficiency and productivity. Durable mobile computers provide workers with access to information anytime, no matter where the task brings them. Wireless connectivity, data collection, and data transfer features allow workers to keep in touch with the operations control all day long. Winmate's rugged mobile computers are built to last, reducing the total cost of ownership over time. Retailers, manufacturers, logistics companies, and field service organizations all choose Winmate mobile computers daily to improve daily operations.



**Rail Box PC**

Intel® Celeron® N2930  
Bay Trail-M Processor



**15" ATEX Panel PC**

Intel® Celeron®  
N2930 Processor  
PCAP touchscreen



**19" ATEX Panel PC**

Intel® Haswell Core™  
i5-4300U

## About Winmate

Founded in 1996, Winmate Inc. is a pioneer in rugged computing technology. For over two decades, Winmate has provided business leaders worldwide with reliable, rugged solutions made for the most challenging industrial conditions. From R&D to manufacturing to in-house testing, Winmate Inc. manages the entire product development process with ready-made products available for quick deployment. Today Winmate's innovative approach has helped countless enterprises at every level with equipment automation and seamless Industrial Internet of Things (IIoT) integration.

Visit [www.winmate.com](http://www.winmate.com)





[www.winmate.com](http://www.winmate.com)

## Contact Us



### Winmate Inc.

No.111, Shing-De Rd.,  
San-Chung District,  
New Taipei City 24158, Taiwan  
**Tel** +886-2-8511-0288  
**E-mail** [sales@winmate.com.tw](mailto:sales@winmate.com.tw)  
**Website** [www.winmate.com](http://www.winmate.com)



### Winmate USA Inc.

2640 Mathews Street,  
Smyrna, GA 30080, USA  
**Tel** +1 678-653-8800  
**E-mail** [NASales@winmate.com.tw](mailto:NASales@winmate.com.tw)  
**Website** [www.winmate-rugged.com](http://www.winmate-rugged.com)



### TTX Canada Inc.

150 Werlich Drive, Units 5&6  
Cambridge, Ontario, N1T 1N6 Canada  
**Tel** +1-519-621-1881  
**E-mail** [Sales@ttx.ca](mailto:Sales@ttx.ca)  
**Website** [www.ttx.ca](http://www.ttx.ca)



### Winmate Germany

Bgm.-Gradl-Straße 1 D-85232  
Bergkirchen-Feldgeding  
**Tel** +49 0 8131 33204-0  
**E-mail** [info@tl-electronic.de](mailto:info@tl-electronic.de)  
**Website** [www.tl-electronic.de/](http://www.tl-electronic.de/)



### 北京京融电自动化科技有限公司

Room 204, Building A,  
Shangdi International Technology Venture Park,  
No. 1, Xixi Road, Haidian District, Beijing City  
**Tel** +86-10-82743702/3802  
**E-mail** [sales@winmate.com.cn](mailto:sales@winmate.com.cn)  
**Website** [www.winmate.com.cn](http://www.winmate.com.cn)